

Biometric Based Finger-vein recognition For Automatic Teller Machine

T.Prasanth¹, R.Praveen Chandran², B.Vigneshwaran³

^{1,2,2}Department of Computer Science and Engineering, SNS College
Coimbatore, Tamil Nadu-641107, India

Abstract:

In this project, a real-time embedded finger-vein recognition system for authentication on teller machine being developed. This system is implemented on an embedded platform and equipped with a novel finger-vein recognition algorithm, so this system is an intelligent security system. Based on this a teller machine concept is developed. Wherein, the transaction is successful, If and only if the finger vein matched via GSM technology.

Key word: Finger –vein recognition, Teller Machine, GSM technology.

1. INTRODUCTION

Automated teller machines (ATMs) are well known devices typically used by Individuals to carry out a variety of personal and business financial transactions and/or banking functions. ATMs have become very popular with the general public for their availability and general user friendliness. ATMs are now found in many locations having a regular or high volume of consumer traffic. For example, ATMs are typically found in restaurants, supermarkets, Convenience stores, malls, schools, gas stations, hotels, work locations, banking centers, airports, entertainment establishments, transportation facilities and a myriad of other locations. ATMs are typically available to consumers on a continuous basis such that consumers have the ability to carry out their ATM financial transactions and/or banking functions at any time of the day and on any day of the week. Private information is traditionally provided by using passwords or Personal Identification Numbers (PINs), which are easy to implement but is vulnerable to the risk of exposure and being forgotten. Biometrics, which uses human physiological or behavioral features for personal identification, has attracted more and more attention and is becoming one of the most popular and promising alternatives to the traditional password or PIN based authentication techniques [1]. Moreover, some multimedia content

in consumer electronic appliances can be secured by biometrics [2].

There is a long list of available biometric patterns, and many such systems have been developed and implemented, including those for the face, iris, fingerprint, palm print, hand shape, voice, signature, and gait. Not with standing this great and increasing variety of biometrics patterns, no biometric has yet been developed that is perfectly reliable or secure. For example, finger prints and palm prints are usually frayed; voice, signatures, hand shapes and iris images are easily forged; face recognition can be made difficult by occlusions or face-lifts [3]; and biometrics, such as fingerprints and iris and face recognition can be are susceptible to spoofing attacks, that is, the biometric identifiers can be copied and used to create Artifacts that can deceive many currently available biometric devices. The great challenge to biometrics is thus to improve recognition performance in terms of both accuracy and efficiency and be maximally resistant to Deceptive practices. To this end, many researchers have sought to improve reliability and frustrate spoofers by developing biometrics that are highly individuating; yet at the same time, present a high complex, hopefully insuperable challenge to those who wish to defeat them [4].

Especially for consumer electronics applications, biometrics authentication systems need to be cost-efficient and easy to implement [5].

The finger-vein is a promising biometric pattern for personal identification in terms of it security and convenience [6]. Compared with other biometric traits, the finger-vein has the following advantages [7]: (1) the vein is hidden inside the body and is mostly invisible to human eyes, so it is difficult to forge or steal. (2) The non-invasive and contactless capture of finger-veins ensures both convenience and hygiene for the user, and is thus more acceptable. (3) The finger-vein pattern can only be taken from a live

body.

Therefore, it is natural and convincing proofs that the subject whose finger-vein is successfully captured is alive. We designed a special device for acquiring high quality finger-vein images and propose a DSP based embedded platform to implement the finger-vein recognition system in the present study to achieve better recognition performance and reduce computational cost.

2. Overview Of The System:

The proposed system consists of three hardware modules: image acquisition module, DSP mainboard, and human machine communication module. The image acquisition module is used to collect finger-vein images. The DSP mainboard including the DSP chip, memory (flash), and communication port is used to execute the finger-vein recognition algorithm and communicate with the peripheral device. The human machine communication module (LED or keyboard) is used to. Display recognition results and receive inputs from users.

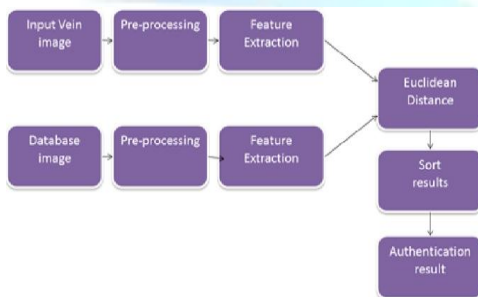

Fig.1.the flow-chart of the proposed recognition algorithm

The proposed finger-vein recognition algorithm contains two stages: the enrollment stage and the verification stage. Both stages start with finger-vein image pre-processing, which includes detection of the region of interest (ROI), image segmentation, alignment, and enhancement.

For the enrollment stage, after the pre-processing and the feature extraction step, the finger-vein template database is built. For the verification stage, the input finger-vein image is matched with the corresponding template after its features are extracted. Fig. 1 shows the flow chart of the proposed algorithm. Some different methods may have been

proposed for finger-vein matching. Considering the computation complexity, efficiency, and practicability, however, we propose a novel method based on the fractal theory, which will be introduced in Section 4 in detail.

3. IMAGE ACQUISITION

To obtain high quality near-infrared (NIR) images, a special device was developed for acquiring the images of the finger vein without being affected by ambient temperature. Generally, finger-vein patterns can be imaged based on the principles of light reflection or light transmission [8].

We developed a finger-vein imaging device based on light transmission for more distinct imaging. Our device mainly includes the following modules: a Monochromatic camera of resolution 580×600 pixels, daylight cut-off filters (lights with the wavelength less than 800 nm are cut off), transparent acryl (thickness is 10 mm), and the NIR light source. The structure of this device is illustrated in Fig. 3. The transparent acryl serves as the platform for locating the finger and removing uneven illumination. The NIR light irradiates the backside of the finger. In [9], a light-emitting diode (LED) was used as the illumination source for NIR light. With the LED illumination source, however, the shadow of the finger-vein obviously appears in the captured images. To address this problem, an NIR laser diode (LD) was used in our system. Compared with LED, LD has stronger permeability and higher power. In our device, the wavelength of LD is 808 nm. Fig. 4 shows an example raw finger-vein image captured by using our device.

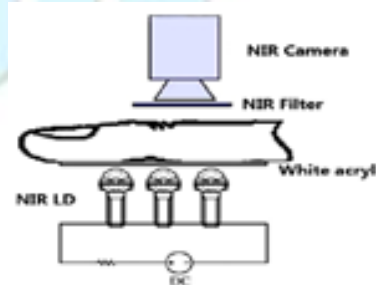

Fig. 2. Illustration of the imaging device

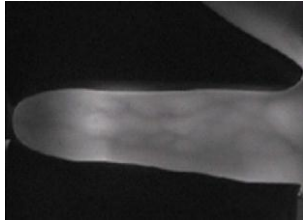

Fig.3.An example raw finger-vein image captured by our device.

4.PROPOSED ALGORITHM

4.1. Image Segmentation and Alignment

Because the position of fingers usually varies across different finger-vein images, it is necessary to normalize the images before feature extraction and matching.

The bone in the finger joint is articular cartilage. Unlike other bones, it can be easily penetrated by NIR light. When a finger is irradiated by the uniform NIR light, the image of the joint is brighter than that of other parts. Therefore, in the horizontal projection of a finger-vein image, the peaks of the projection curve correspond to the approximate position of the joints. Since the second joint of the finger is thicker than the first joint, the peak value at the second joint is less prominent. Hence, the position of the first joint is used for determining the position of the finger.



Fig.4.The segmented ROI of the finger-vein image.

The alignment module includes the following steps. First, the part between the two joints in the finger-vein image is segmented based on the peak values of the horizontal projection of the image.

Second, a canny operator with locally adaptive threshold is used to get the single pixel edge of the finger. Third, the midpoints of finger edge are determined by edge tracing so that the midline can be obtained. Fourth, the image is rotated to adjust the midline of the finger horizontally. Finally, the ROI of

the finger-vein image is segmented according to the midline (see Fig.4).

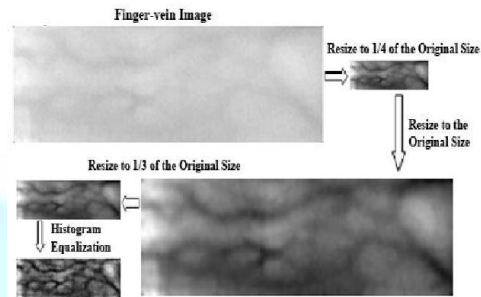

Fig.5.The procedure of our method for image enhancement

4.2. Image Enhancement

The segmented finger-vein image is then enhanced to improve its contrast as shown in Fig. 7. The image is resized to 1/4 of the original size, and enlarged back to its original size. Next, the image is resized to 1/3 of the original size for recognition. Bicubic interpolation is used in this resizing procedure. Finally, histogram equalization is used for enhancing the gray level contrast of the image.

4.3 Transformation Techniques

Input vein texture features are usually using simple mean method and Discrete Wavelet Transform

$$Z(t)=x(t) * y(t)$$

Where z is the level of the object, x is x -coordinate value, y is y -coordinate value of the image.

4.4 Matching

The wavelet transform distance HD between two finger vein patterns and the energy feature distance H are defined as

$$HD = \sum_{\epsilon=2}^4 \sum_{i,j} |D_{1\epsilon}(i,j) - D_{2\epsilon}(i,j)|$$

$$HA = \sum_{\varepsilon=2}^4 \sum_{i,j} |A_{1\varepsilon(i,j)} - A_{2\varepsilon(i,j)}|$$

In our method, the dimension and energy features are combined for finger-vein recognition: if $HD_{th1} = th2$, then the two finger vein patterns are considered to be from the same finger; if $HD_{th1} < \text{or} > th2$, then they are considered to be from different fingers.

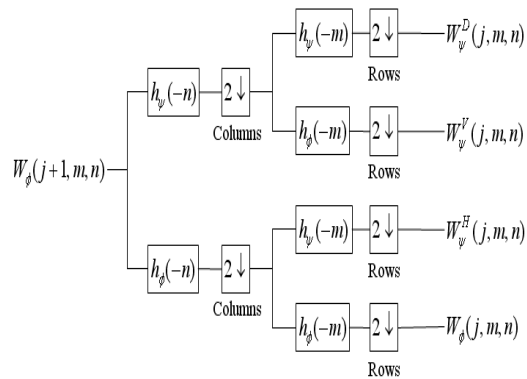

Fig.6. Wavelet Transform in two dimension

5. EXPERIMENTAL RESULTS

5.1 Dataset

To the best of our knowledge, is no public finger-vein image database has yet been introduced. Therefore, we constructed a finger-vein image database for evaluation, which contains finger-vein images from 100 subjects (55% male and 45%female) from a variety of ethnic/racial ancestries.

The ages of the subjects were between 21 years old and 58 years old. We collected we collected finger-vein images from the forefinger, middle finger, and ring finger of both hands of each subject. Ten images were captured for each finger at different times (summer and winter). Therefore, there were a total of 6,000finger-vein images in the database. Fig. 8 shows some example finger-vein images (after preprocessing) from different fingers.

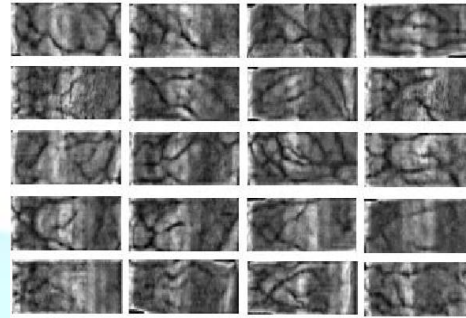

Fig. 7. Finger-vein images from different fingers after preprocessing

5.3. Comparison with Previous Methods

Miura et al. [19] used a database that contained 678 different infrared images of fingers. These images were obtained from persons working in their laboratory aged 20 to 40, approximately 70% of whom were male. Song's [20] finger-vein image dataset contained 1,125 images collected using an infrared imaging device they built. Nine images were taken for each of 125 fingers. Compared with these databases, ours is larger and the data-collection interval is longer. Thus, our database is more challenging. Moreover, our system is implemented on a general DSP chip. Moreover it is implemented on Automatic Teller Machine where previous method was use for mobile devises. GSM module is used to send authentication message to the author. High security is provided using GSM tecnolgy.

6. Conclusion

The present study proposed an end-to-end finger-vein recognition system based on the wavelet transformation and energy feature implemented on a DSP platform. A novel method combining wavelet transformation and energy features for recognition. By increasing the GSM signals we can avoid out of coverage problems on mobile device. Our system is suitable for application in Teller Machines because of its relatively low computational complexity.

REFERENCES

- [1] Heljmans and Goutsias, "Nonlinear Multi resolution Signal Decomposition Scheme - Part II: Morphological Wavelets," IEEE Transactions on Image Processing, vol. 9, No. 11, November 2000.
- [2] David Zhang, Palm print Authentication, Kluwer Academic Publishers: Boston, 2004, pp.195.
- [3] Nicolae Duta, Anil K. Jain and Kanti V. Mardia, "Matching of Pattern Recognition Letters 23, 2002, pp. 477-485.
- [4] A. K. Jain, S. Pankanti, S. Prabhakar, H. Lin, and A. Ross, "Biometrics: a grand challenge", Proceedings of the 17th International Conference on Pattern Recognition (ICPR), vol. 2, pp. 935-942, 2004.
- [5] P. Corcoran and A. Cucos, "Techniques for securing multimedia content in consumer electronic appliances using biometric signatures," IEEE Transactions on Consumer Electronics, vol 51, no. 2, pp. 545-551, May 2005.
- [6] Y. Kim, J. Yoo, and K. Choi, "A motion and similarity-based fakedetection method for biometric face recognition systems," IEEE Transactions on Consumer Electronics, vol.57, no.2, pp.756-762, May 2011.
- [7] D. Wang, J. Li, and G. Memik, "User identification based on finger vein patterns for consumer electronics devices", IEEE Transactions on Consumer Electronics, vol. 56, no. 2, pp. 799-804, 2010.
- [8] H. Lee, S. Lee, T. Kim, and Hyokyung Bahn, "Secure user identification for consumer electronics devices," IEEE Transactions on Consumer Electronics, vol.54, no.4, pp.1798-1802, Nov. 2008.
- [9] D. Mulyono and S. J. Hornig, "A study of finger vein biometric for personal identification", Proceedings of the International Symposium Biometrics and Security Technologies, pp. 134-141, 2008.
- [10] Z. Liu, Y. Yin, H. Wang, S. Song, and Q. Li, "Finger vein recognition with manifold learning", Journal of Network and Computer Applications, vol.33, no.3, pp. 275-282, 2010.
- [11] Y. G. Dai and B. N. Huang, "A method for capturing the finger-vein image using nonuniform intensity infrared light", Image and Signal Processing, vol.4, pp.27-30, 2008.
- [12] X. Sun, C. Lin, M. Li, H. Lin, and Q. Chen, "A DSP-based finger vein authentication system", Proceedings of the Fourth International Conference [13] B. B. Mandelbrot, Fractals: Form, Chance and Dimension, San Francisco, CA: Freeman, 1977.
- [13] B. B. Mandelbrot, Fractals: Form, Chance and Dimension, San Francisco, CA: Freeman, 1977.
- [14] B. B. Mandelbrot and D. Stauffer, "Antipodal correlations and the texture (fractal lacunarity) in critical percolation clusters", Journal of Physics A: Mathematical and General, vol.27, pp.237-242, 1994.
- [15] J. Berke, "Using Spectral Fractal Dimension in Image Classification", Innovations and advances in computer sciences and engineering, pp. 237-241, 2010.
- [16] Z. Feng, "Variation and Minkowski dimension of fractal interpolation surface", Journal of Mathematical Analysis and Applications, vol. 345, no.1, pp. 322-334, 2008.
- [17] S. Peleg and J. Naor, "Multiple resolution texture analysis and classification", IEEE Transactions on Pattern Analysis and Machine Intelligence, vol.6, no.4, pp.518-523, 1984.
- [18] C. Allain and M. Cloitre, "Characterizing the lacunarity of random and deterministic fractal sets", Physical Review A, vol.44, no.6, pp. 3552- 3558, 1991.
- [19] K. I. Kilic and R. H. Abiyev, "Exploiting the synergy between fractal dimension and lacunarity for improved texture recognition", Signal Processing, vol. 91, no. 10, pp. 2332-2344, 2011.
- [20] Novianto, Suzuki, and Maeda, "Optimum estimation of local fractal dimension based on the blanket method," Transactions of the Information Processing Society of Japan, vol. 43, no.3, pp. 825-828, 2002.
- [21] D. D. Hwang and I. Verbauwhede, "Design of portable biometric authenticators - energy, performance, and security tradeoffs," IEEE Transactions on Consumer Electronics, vol. 50, no. 4, pp. 1222-1231, Nov. 2004.
- [22] N. Miura, A. Nagasaka, and T. Miyatake, "Feature extraction of finger vein patterns based on repeated line tracking and its application to personal identification", Machine Vision Application, vol. 15, no.4, pp.194-203, 2004.
- [23] W. Song, T. Kim, H. C. Kim, J. H. Choi, H. Kong and S. Lee, "A finger-vein verification system using mean curvature", Pattern Recognition Letters, vol. 32, no.11, pp. 1541-1547, 2011.